

# SCHÉMA DE CONNEXION

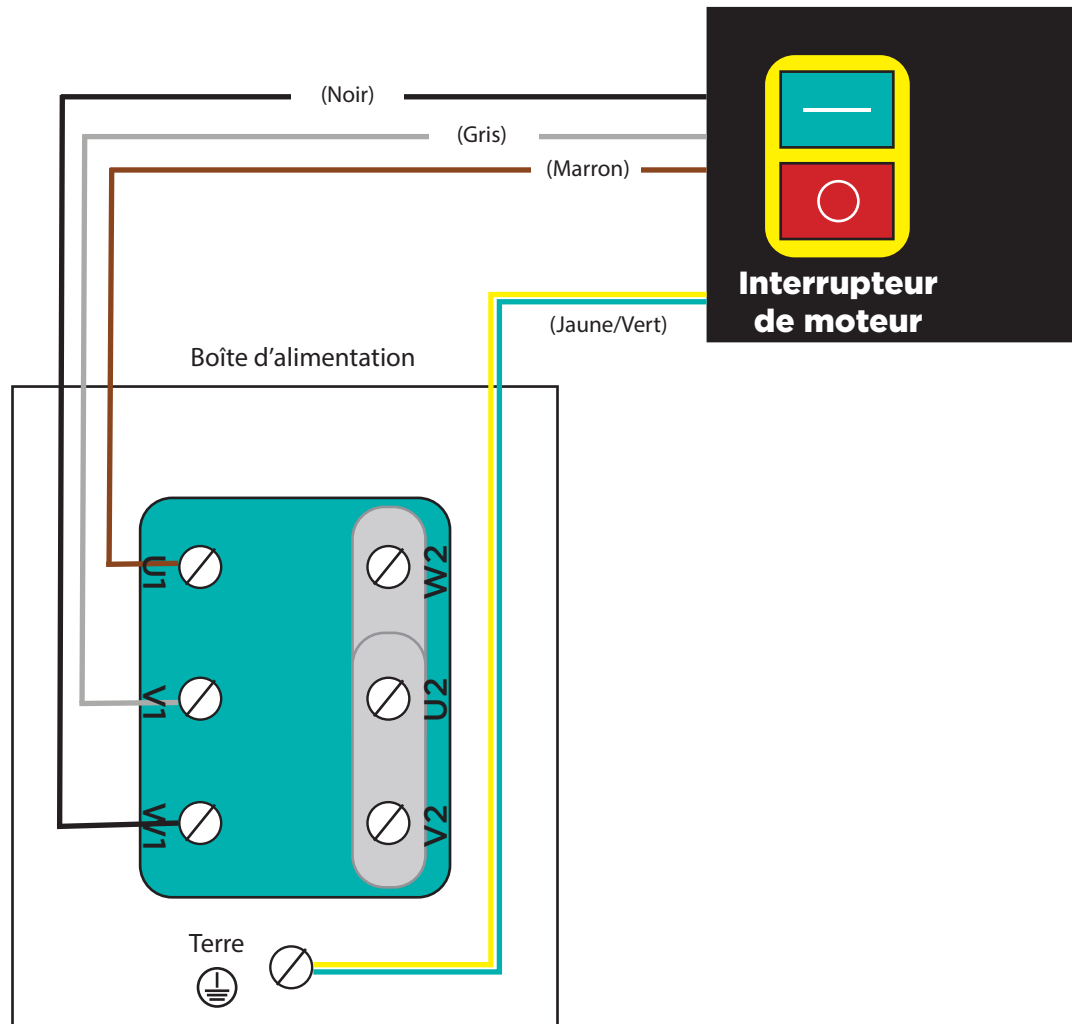

FR - 20.09.24

MALAXEURS À ACTION FORCÉE 400V, 2.2KW, 200L



Voir les photos à la page suivante..

**SUPPORT COMMERCIAL / ADMINISTRATION**  
FABRIKSPARKEN 13 DK-2600 GLOSTRUP  
+45 36 72 75 00 SALES@SOROTO.DK

**PRODUCTION / ENTREPÔT**  
FABRIKSPARKEN 11 DK-2600 GLOSTRUP  
+45 36 72 78 00 TEKNIK@SOROTO.DK

SOROTO@SOROTO.DK WWW.SOROTOMACHINERY.FR

